

## BIG STRAWBERRY



|  |  |
|--|--|
| 1 Antriebsrad                                      | 1 roue motrice                               |
| 1 Motor 600 W S2 + Motorschutz                     | 1 moteur 600 W S2 + thermique                |
| Bereifung 2x5.00/15                                | Pneus 2x5.00/15                              |
| 4 Ernteplätze                                      | 4 postes de travail                          |
| CAB3 - Motor + Batterien + Diagnostik              | CAB3 - Moteur + Batteries + Diagnostic       |
| Erntegeschwindigkeit von 0 bis 1,2 km/h            | Vitesse de récolte de 0 à 1,2 km/h           |
| Fahrtrichtungswahler mit elektronischer Bremse     | Inverseur avec frein électronique            |
| 4 Pedale "Stop&Go" + Geschwindigkeitspotenziometer | 4 pédales "Stop&Go" et potentiomètre vitesse |
| 4 Kistenträger                                     | 4 supports pour caisses                      |
| Hochfrequenz-Ladegerät 24/25                       | Chargeur de batterie 24/25 haute fréquence   |
| Sonderausstattung: Ladegerät IP65                  | Option: chargeur de batterie IP65            |



|   |   |
|---|---|
| Single wheel drive                              | 1 ruota motrice                             |
| 1 x 600 W S2 motor + thermal protection         | 1 motore 600 W S2 + termica                 |
| Tyres 2x5.00/15                                 | Ruote da 2x5.00/15                          |
| 4 harvesting positions                          | 4 postazioni di lavoro                      |
| CAB3 - Motor + Batteries + Diagnostic           | CAB3 - Motore + Batterie + Diagnostica      |
| Harvesting speed: 0 to 1.2 km/h                 | Velocità da 0 a 1,2 km/h                    |
| Speed reverse control with electronic brake     | Inversore con freno elettronico             |
| 4 "Stop&Go" foot controls + speed potentiometer | 4 pedali "Stop&Go" e potenziometro velocità |
| 4 box supports                                  | 4 portacasse                                |
| 24/25 high frequency battery charger            | Caricabatteria 24/25 alta frequenza         |
| Optional: IP65 battery charger                  | Optional: caricabatteria IP65               |

■ Standard

□ Optional

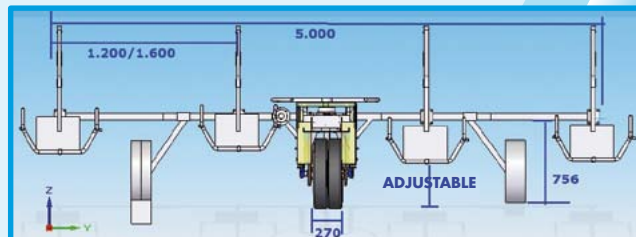

## TRANSPALLET (4 BINS)



Rimorchio autocaricante



Remorque à chargement automatique



Trailer with automatic loading



Anhänger mit Autobeladung

### DIMENSIONI ABMESSUNGEN - DIMENSIONS

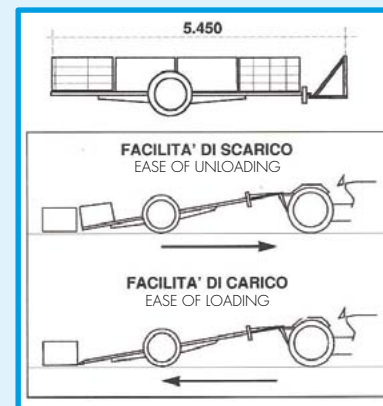

# Bagioni

## Forlì-Italy

Viale Bologna, 100 - 47122 Forlì (ITALY)  
Tel. 0039 0543 703993 - Fax 0039 0543 702182  
Mail: bagioni.aureno@libero.it  
Web: [www.asparagus.it](http://www.asparagus.it)



UNSERE FORSCHUNG

LA NOSTRA RICERCA

OUR RESEARCH

NOTRE RECHERCHE





## FILM HANDLING SYSTEM



|                              |                                     |                          |
|------------------------------|-------------------------------------|--------------------------|
| Doppelreihe                  | <input checked="" type="checkbox"/> | Double rang              |
| Dachsystem                   | <input checked="" type="checkbox"/> | Système de couverture    |
| Öffnungssystem               | <input checked="" type="checkbox"/> | Système d'ouverture      |
| System in wechselnden Reihen | <input checked="" type="checkbox"/> | Système à rangs alternés |



|                      |                                     |                        |
|----------------------|-------------------------------------|------------------------|
| Double row           | <input checked="" type="checkbox"/> | Doppia fila            |
| Covering system      | <input checked="" type="checkbox"/> | Sistema di copertura   |
| Opening system       | <input checked="" type="checkbox"/> | Sistema di apertura    |
| Alternate row system | <input checked="" type="checkbox"/> | Sistema a file alterne |

Standard

Optional

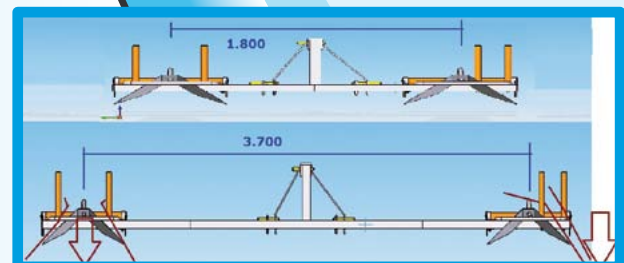

## ZUCC-INDUSTRY



|  |                                     |  |
|--|-------------------------------------|--|
| 2 Antriebsräder                                    | <input checked="" type="checkbox"/> | 2 roues motrices                             |
| 2 Motoren 600 W S2 + Motorschutz                   | <input checked="" type="checkbox"/> | 2 moteurs 600 W S2 + thermique               |
| Bereifung 13"                                      | <input checked="" type="checkbox"/> | Pneus 13"                                    |
| Tragkraft 300 kg                                   | <input checked="" type="checkbox"/> | Capacité 300 kg                              |
| CAB3 - Motor + Batterien + Diagnostik              | <input checked="" type="checkbox"/> | CAB3 - Moteur + Batteries + Diagnostic       |
| Erntegeschwindigkeit von 0 bis 3 km/h              | <input checked="" type="checkbox"/> | Vitesse de récolte de 0 à 3 km/h             |
| Fahrtrichtungsschalter mit elektronischer Bremse   | <input checked="" type="checkbox"/> | Inverseur avec frein électronique            |
| 2 Pedale "Stop&Go" + Geschwindigkeitspotenziometer | <input checked="" type="checkbox"/> | 2 pédales "Stop&Go" et potentiomètre vitesse |
| 2 Kistenträger                                     | <input checked="" type="checkbox"/> | 2 supports pour caisses                      |
| Hochfrequenz-Ladegerät 24/25                       | <input checked="" type="checkbox"/> | Chargeur de batterie 24/25 haute fréquence   |
| Sonderausstattung: Ladegerät IP65                  | <input type="checkbox"/>            | Option: chargeur de batterie IP65            |
| Förderband   | <input checked="" type="checkbox"/> | Convoyeur à tapis                            |
| Kippbehälter (Fassungsvermögen 270 kg)             | <input checked="" type="checkbox"/> | Bac basculant (capacité 270 kg)              |



|   |                                     |   |
|---|-------------------------------------|---|
| 2-wheel drive                                   | <input checked="" type="checkbox"/> | 2 ruote motrici                             |
| 2 x 600 W S2 motors + thermal protection        | <input checked="" type="checkbox"/> | 2 motori 600 W S2 + termica                 |
| 13" tyres                                       | <input checked="" type="checkbox"/> | Ruote da 13"                                |
| 300 kg capacity                                 | <input checked="" type="checkbox"/> | Portata 300 kg                              |
| CAB3 - Motor + Batteries + Diagnostic           | <input checked="" type="checkbox"/> | CAB3 - Motore + Batterie + Diagnostica      |
| Harvesting speed: 0 to 3 km/h                   | <input checked="" type="checkbox"/> | Velocità da 0 a 3 km/h                      |
| Speed reverse control with electronic brake     | <input checked="" type="checkbox"/> | Inversore con freno elettronico             |
| 2 "Stop&Go" foot controls + speed potentiometer | <input checked="" type="checkbox"/> | 2 pedali "Stop&Go" e potenziometro velocità |
| 2 box supports                                  | <input checked="" type="checkbox"/> | 2 portacasse                                |
| 24/25 high frequency battery charger            | <input checked="" type="checkbox"/> | Caricabatteria 24/25 alta frequenza         |
| Optional: IP65 battery charger                  | <input type="checkbox"/>            | Optional: caricabatteria IP65               |
| Belt conveyor                                   | <input checked="" type="checkbox"/> | Nastro trasportatore                        |
| 270kg capacity tilting box                      | <input checked="" type="checkbox"/> | Cassone ribaltabile (270 kg)                |

Standard

Optional

## ZUCC-FRESH/MARKET



|  |                                     |  |
|--|-------------------------------------|--|
| 2 Antriebsräder                                    | <input checked="" type="checkbox"/> | 2 roues motrices                                 |
| 2 Motoren 600 W S2 + Motorschutz                   | <input checked="" type="checkbox"/> | 2 moteurs 600 W S2 + thermique                   |
| Bereifung 13"                                      | <input checked="" type="checkbox"/> | Pneus 13"  |
| Tragkraft 300 kg                                   | <input checked="" type="checkbox"/> | Capacité 300 kg                                  |
| CAB3 - Motor + Batterien + Diagnostik              | <input checked="" type="checkbox"/> | CAB3 - Thermique moteur + Batteries + Diagnostic |
| Erntegeschwindigkeit von 0 bis 3 km/h              | <input checked="" type="checkbox"/> | Vitesse de récolte de 0 à 3 km/h                 |
| Fahrtrichtungsschalter mit elektronischer Bremse   | <input checked="" type="checkbox"/> | Inverseur avec frein électronique                |
| 2 Pedale "Stop&Go" + Geschwindigkeitspotenziometer | <input checked="" type="checkbox"/> | 2 pédales "Stop&Go" et potentiomètre vitesse     |
| 2 Kistenträger                                     | <input checked="" type="checkbox"/> | 2 supports pour caisses                          |
| Hochfrequenz-Ladegerät 24/25                       | <input checked="" type="checkbox"/> | Chargeur de batterie 24/25 haute fréquence       |
| Sonderausstattung: Ladegerät IP65                  | <input type="checkbox"/>            | Option: chargeur de batterie IP65                |



|   |                                     |   |
|---|-------------------------------------|---|
| 2-wheel drive                                   | <input checked="" type="checkbox"/> | 2 ruote motrici                             |
| 2 x 600 W S2 motors + thermal protection        | <input checked="" type="checkbox"/> | 2 motori 600 W S2 + termica                 |
| 13" tyres                                       | <input checked="" type="checkbox"/> | Ruote da 13"                                |
| 300 kg capacity                                 | <input checked="" type="checkbox"/> | Portata 300 kg                              |
| CAB3 - Motor + Batteries + Diagnostic           | <input checked="" type="checkbox"/> | CAB3 - Motore + Batterie + Diagnostica      |
| Harvesting speed: 0 to 3 km/h                   | <input checked="" type="checkbox"/> | Velocità da 0 a 3 km/h                      |
| Speed reverse control with electronic brake     | <input checked="" type="checkbox"/> | Inversore con freno elettronico             |
| 2 "Stop&Go" foot controls + speed potentiometer | <input checked="" type="checkbox"/> | 2 pedali "Stop&Go" e potenziometro velocità |
| 2 box supports                                  | <input checked="" type="checkbox"/> | 2 portacasse                                |
| 24/25 high frequency battery charger            | <input checked="" type="checkbox"/> | Caricabatteria 24/25 alta frequenza         |
| Optional: IP65 battery charger                  | <input type="checkbox"/>            | Optional: caricabatteria IP65               |

Standard

Optional

